

COARSE MINCER

SERIES 255

TECHNICAL INFORMATION

Capacity: up to 10 000 kg/h and has an automatic feed which makes it possible to empty a container of up to 800 litres into the feed hopper.

Motor: 4 kW for cutting knife.
Motor: 7,5 kW for feed screw.

Stepless speed control for cutting knife.

Cutting head diam.: 280 mm.

Total length: 1480 mm
Total width: 860 mm
Total height: 1620 mm
Net weight: 900 kg
Shipping volume: 2,8 m

DESIGN

The mincer is driven by two separate motors, one motor for the feed screw which has constant low speed and one motor for the cutting knife with speed control from 40 rpm to 180 rpm.

THE CUTTING HEAD

The cutting head with the independent knife, which has a variable speed, in combination with the different sizes of hole in the cutting plate, makes it possible to achieve the desired size of cut raw material, eg. for tumbled ham in pieces.

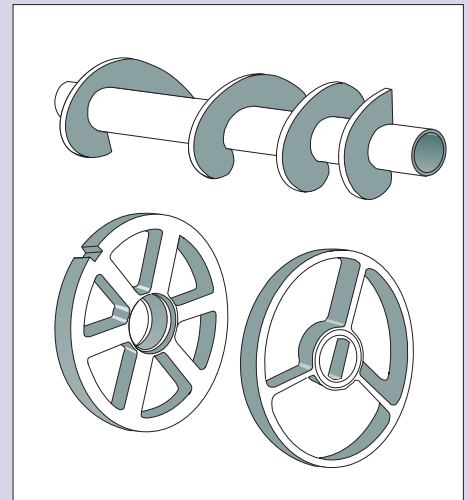
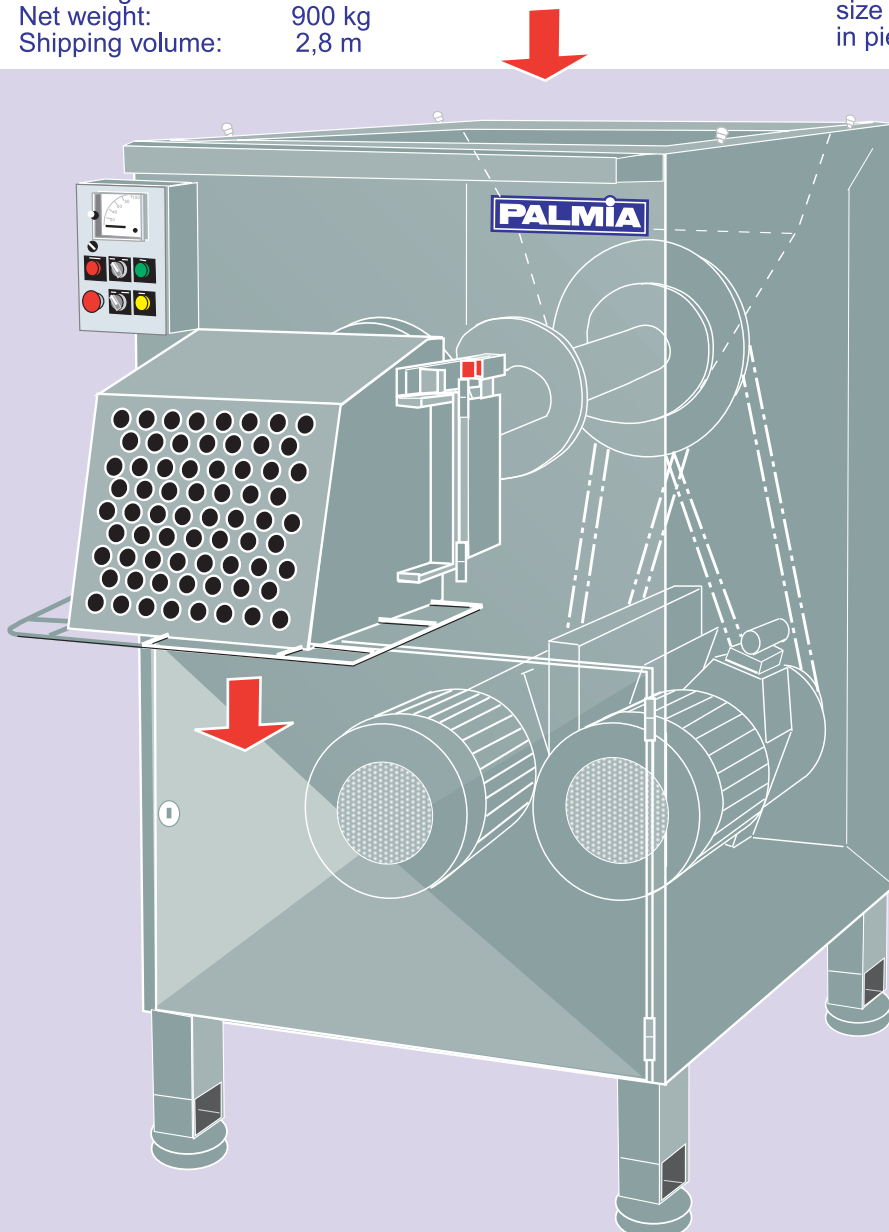

Palmiatek Oy Ltd

Sepänpellontie 19
28430 PORI, FINLAND
Tel. +358 207 559 100
Fax. +358 2 550 7350
E-mail: palmia@palmiatek.fi

COARSE MINCER

SERIES 255

GENERAL

To achieve optimum standardisation/uniformity of meat products, the meat has to be cut correctly into evenly/sized pieces without having been pressed.

Expensive and complicated, low-capacity dicing machines are often used for this task.

Discharge shield is standard. An extra feed hopper is obtainable with the size adapted to the customer's requirements. The standard feed hopper holds 165 litres.

The standard model of the mincer is made of stainless steel. The feed screw and the cutting head, however, are made of tool steel. The feed screw is also obtainable in stainless.

EXTRAS

Extra feed hopper.
Hoist for feeding the mincer.
Stainless feed screw.

